



Evolution3 accuracy in a portable cutter

The Evolution3 FreeHand has been designed for those who require the high precision accuracy and superior cutting quality of the Evolution3 range but in a more flexible format.

It is perfect for a workshop where the cutter bar is required to move between workbenches.

Evolution3 FreeHand gives you all the benefits of the QuikSwap cutting tools, sightline strip accuracy and anti-sag design in a portable cutter.

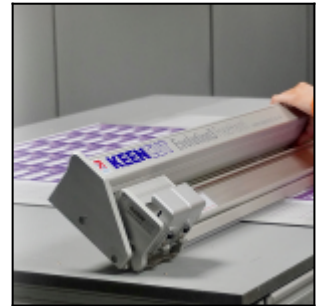
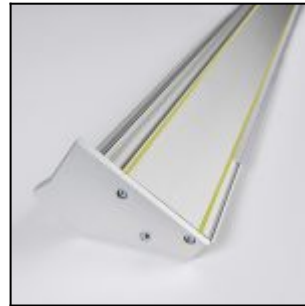
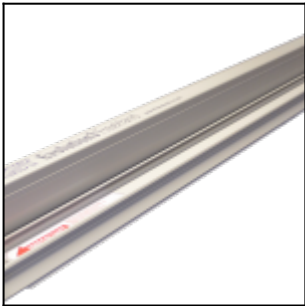

Materials cut

Semi-rigid materials

Corrugated cardboard ≤ 13mm (1/2")

PVC foamboard ≤ 13mm (1/2")

Corrugated plastic ≤ 13mm (1/2")

Foam centred board ≤ 13mm (1/2")

Rigid materials

Cast acrylic / Plexiglas ≤ 3mm (3/32") scoring only

Flexible materials

Banners

Pop-ups

Magnetic sheets

Film

Self-adhesive vinyls

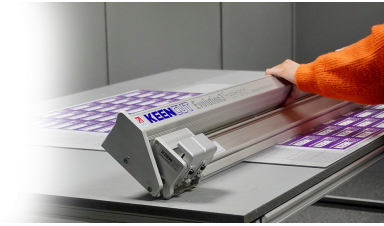

Guaranteed accuracy

The Evolution3 is the most accurate cutter of its type on the market and is guaranteed to cut within 0.2mm (0.008") of a straight line for the length of the cut. The in-built ultra-precision accuracy combined with the perfect alignment, made possible using the sightline strip, means every butt-jointed panel will join seamlessly. This ultra-precision accuracy will save you time and money with less waste and fewer mistakes.

Total stability

The self-adjusting track roller system fitted to the QuikSwap tool heads provides a strong and smooth movement up and down the length of the cutter bar, with zero sideways movement to ensure a perfect straight line. This, coupled with rigid blade clamping gives perfect blade control and spot-on accuracy, so less wastage and mistakes. On the FreeHand, the underside of the cutter bar has two silicone strips that will grip to the material surface preventing any chance of it slipping.

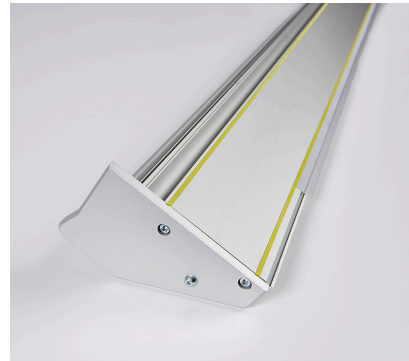

Simple to use

The ease of use makes it possible for even first time users to cut confidently and accurately with the Evolution3 FreeHand. The sightline strip guides you to achieve perfect accuracy and the heavy base and solid structure create a stable cutting platform.

Heavy duty reliability

The entire Evolution3 range has been built to last using high quality materials and well tested engineering principles. The cutting head bearing system guarantees perfect blade control even with the most difficult of materials.

Keencut make the majority of components on its high-tech CNC machines keeping tolerances and quality under constant control, this assures exceptional accuracy and total reliability.



QuikSwap Double Graphik tool head

The Evolution3 Double Graphik tool head comes as standard and has two individual blade holders for two-way cutting. The blades are stronger and more stable than regular blades making the Double Graphik tool ideal for vinyl, banner, cardboard, PVC foamboard up to 13mm (1/2"), foam-centred board, corrugated plastic, paper, pop-up and roll-up materials.

Optional Evolution3 tool heads

Evolution3 QuikSwap tool heads give users the ultimate flexibility. Each tool is designed for a specific purpose and can be attached or detached from the cutter in seconds

Evolution3 Fabric tool head is ideal for cutting fabric, paper, film, vinyl, banners and delicate materials. With the Evolution3 BenchTop and FreeHand, the Fabric tool head should be used in conjunction with a cutting mat.

Evolution3 Rocker tool head is a general-purpose tool for cutting materials such as banners, cardboard and foamboard up to 10mm (3/8"). A Tech-D.012 blade can be used for the occasional cutting of aluminium composite panels, such as Dibond or Alupanel. **Evolution3 Creaser tool head** will crease in both directions and is ideal for stout paper, card, cardboard, and grey board.



Five year guarantee

Like all Keencut machines, the Evolution3 is precision built using top quality materials. All components are manufactured in-house to ensure quality and Evolution3 cutters come with a five year comprehensive guarantee.

In the box

100 Graphik blades
Double Graphik tool head (mounted)

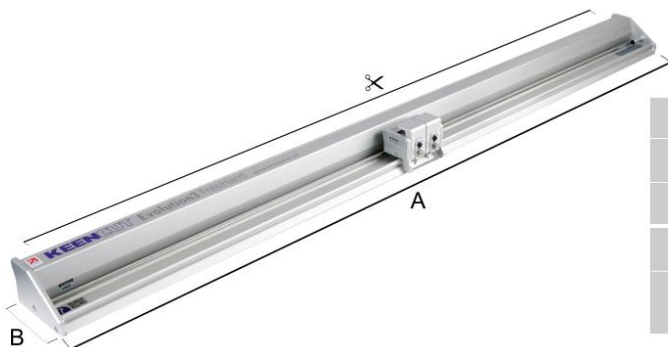

	E3FH110	E3FH160	E3FH210	E3FH260	E3FH310
✂ Cut Length cm (")	110 (44)	160 (64)	210 (84)	260 (104)	310 (124)
A cm (")	142 (56)	192 (75.5)	242 (95)	292 (115)	342 (134.5)
B cm (")	15.5 (6)	15.5 (6)	15.5 (6)	15.5 (6)	15.5 (6)
Packed Weight KG (lbs)	22 (48.5)	28 (62)	34 (75)	40 (88)	46 (101)
Packed Dimensions cm (")	154x35x17 (61x14x7)	204x35x17 (80x14x7)	254x35x17 (100x14x7)	304x35x17 (120x14x7)	354x35x17 (140x14x7)